



# M-100

## Adjustable flow switch with right-angle flow



## Operating Instructions and Quick Start Guide

**Corporate Headquarters**  
1060 S Rogers Circle  
Boca Raton, FL 33487  
P: (561) 995-0595 F: (561) 995-0622

**West Coast Headquarters**  
2329 Zanker Road  
San Jose, CA 95131  
P: (408) 970-3419 F: (408) 970-3426

**South East Asia Headquarters**  
35, Marsiling Industrial Estate Road 3,  
02-06, Singapore 739257  
P: (65) 6482-3533 F: (65) 6484-4231

**India Headquarters**  
3rd Floor Hanumathra Arcade, # 17&18,  
60 Feet Road, Pattegarapalya Main Road,  
Vijayanagar North, Bangalore 560079  
P: (91) 80 2350-4361 F: (91) 802301 1205

# Table of Contents

|                                 |           |
|---------------------------------|-----------|
| <b>Introduction</b>             | <b>03</b> |
| <b>Operation</b>                | <b>03</b> |
| <b>Storage and Handling</b>     | <b>03</b> |
| <b>Installation Instruction</b> | <b>03</b> |
| <b>Specification</b>            | <b>05</b> |
| <b>Certification</b>            | <b>06</b> |
| <b>Dimensional drawings</b>     | <b>07</b> |
| <b>Ordering Information</b>     | <b>07</b> |
| <b>Warranty</b>                 | <b>08</b> |

## Introduction

The M-100 Series flow switches are engineered and field tested for sensing increasing and decreasing flow rates of gases or liquids. Pressure variation effects are minimal. This series features such versatility, economy, and accuracy that they can be used in virtually any application requiring fool-proof inexpensive flow detection.

## Operation

The magnetic piston rests at the bottom of the switch with no flow present. Once flow is established, the piston moves upward responding to a by-pass flow and actuates the reed switch. The by-pass flow is controlled by a manual adjusting screw controlling the variable orifice. When flow decreases, the piston moves downward and the reed switch deactuates. Universal mounted units are outfitted with a spring which resets the piston.

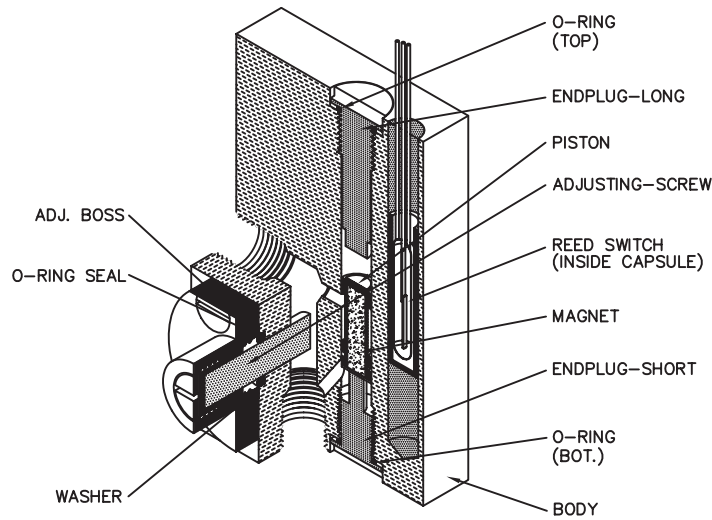

Illustrated is the M-100 Model with 1/8" ports.

## Storage and Handling

### Storage conditions

Store the product under packed condition in an anti-static bag. The storage place shall be free from moisture, mechanical shock and vibration. The ambient temperature shall be between 0°C and 60°C and the humidity between 5% and 80% R.H. without condensation.

### Unpacking and Product Inspection

On delivery, check the product for damage. Confirm that the model code on the label matches the specification in the purchase order.

## Installation Instructions

This product is mounted vertically, models suitable for **Universal mounting** are available on request. Adequate filtration and sealing procedures should be used when mounting in flow line. To ensure protection of malema flow switches from moisture penetration of lead wires, a suitable connector or adaptor fitted to a electrical conduit should be used.

Mounting holes may be drilled if needed as shown in fig. 1 on page 3.

### Adjustment procedure to set actuation point

(These switches must be set with a flow meter. Factory will set your switch on request)

#### For Increasing flow

1. Turn adjustment screw (see diagram above) counter clockwise to full open
2. Establish flow through the switch at nominal flow rate desired by setting the flowmeter to flow rate desired.
3. Turn Adjustment screw clockwise gradually until switch activates.
4. Verification: Turn off/reduce flow through flow switch and re-establish flow to verify that the flow switch is switching at the desired flow rate. The adjustment screw may need to be adjusted very slightly clockwise or counter-clockwise to achieve greater accuracy in the setting.

#### For decreasing flow

Repeat steps 1 to 4.

5. Turn adjustment screws counter-clockwise until switch deactivates.

## SPST vs SPDT

The standard unit is provided with a **SPST N.O.** (N.O = Normally open at rest) dry reed switch. Increasing flow past point will close (activate) the switch. Decrease flow will open (de-activate) the switch).

**SPST NC.** (N.C = Normally close at rest) models are closed at rest. Increasing flow pass set point opens the switch and decreasing flow to set point will close the switch( Typically used to detect loss of flow condition in overall systems)

**SPDT** (Single Pole Double Throw) switches have both N.O. & N.C. configurations by using a common pole along with two additional poles to achieve this dual capability.

## Conversion from N.O. (Normally Open) to N.C. (Normally closed)

1. Loosen allen set screws (4 - 40) on face of body. These are the set screws holding the reed switch in place.
2. Move the reed switch downwards until it shows a closed contact on the multi-meter.
3. Tighten (4 - 40) allen set screws on face of the body.
4. Cycle until on and off by turning upside down to simulate flow. This may necessitate some refinement of the exact location of the reed switch as determined in step 2.

## Precautions during installation

1. Avoid any foreign particles during installation.
2. Large metallic and/or magnetic fields may affect the principle of operation of these units. if disturbance is detected, magnetic shielding may be necessary to ensure correct operation of the flow switch.
3. During installation of explosion proof versions carefully screw in the conduit connector for the electrical leads piping so as to avoid damaging the reed switch leads or reed switch capsule which may lead to shorting the switch installation. 6 (Six threads) have been provided for installation.
4. Electrical ratings etc. have been discussed later in this bulletin. it is advisable to keep within those ratings as excessive power will FRY the switch.

## Electrical Protection/Ratings

The electrical Reed Switch is rated for several million cycles and should rarely require replacement. Most switch failures are the result of overloading. DO NOT EXCEED RATED CAPACITY, as this will cook the REED SWITCH, Catalogue ratings are based upon D.C. resistive loads, however A.C. loads are also commonly switched.

Inductive load switching- Unless appropriate contact protection is provided with either a diode or R.C. network, inductive load switching will cause the contacts to stick.

Capacitive load switching - The static capacitance in cables may cause permanent or intermitter contact sticking. Contacts may be protected by a series surge protector of 0.5 to 5 mA, depending on the load. in some instances, a 10-500 ohm resistor can replace the surge suppressor.

## Cleaning

Cleaning the flow switch is easily accomplished without removing from the line. By unscrewing the clean out plug, the magnetic piston may be removed and the flow passage flushed or cleaned. Care should be taken to thoroughly clean the piston before replacing ( replace the piston as shown in see page 3 figure 2. if the piston is replaced incorrectly, incorrect operation will result).

1. A magnet may be used to remove the magnetic piston.
2. PTFE end plugs (on PTFE models) should not be over tightened.

## Reed Switch Replacement

For reed Switch replacement

1. Loosen allen set screws (4-40) on face of body.
2. Remove and replace reed switch if needed.
3. **Normally Open**  
Move switch downward until switch closes then move upward until switch opens. Very gently retighten allen screws.
- Normally Closed**  
Move switch downward until it closes then move upward very slightly maintaining a closed contact. Very gently retighten allen screws.
4. If possible cycle unit on and off to test. if unit is not installed, turning upside down will simulate the flow.

# Specification

## Construction Materials

|  |   |               |                            |
|--|---|---------------|----------------------------|
| Housing  | Brass   | 316SS         | PTFE                       |
| Endplugs   | Brass   | 316SS         | PFA                        |
| Piston   | 316SS   | 316SS         | PTFE                       |
| Spring<br>(Only in Universal Mounting version)       | Stainless Steel   |               | N/A                        |
| Adjustment Screw (wetted area)                       | PTFE  |               |                            |
| O-rings  | Buna N  | Viton         | PTFE Encapsulated and PTFE |
| <b>Pressure and Temperature Specifications</b>       |   |               |                            |
| Maximum Operating (psig)                             | 1,500   | 3,000         | 80                         |
| Burst (psig)   | 3,000   | 5,000         | 160                        |
| Maximum Operating Temperature                        | 149 C (300°F)   | 149 C (300°F) | 104 C (220°F)              |
| Reed Switch Data (Electrical Ratings)<br>Reed Switch | 10 Watts SPST or 3 Watts SPDT (Hermetically Sealed) UL Recognized. File E47258.<br>Operating Temperature -40°C to 125°C |               |                            |
| Switching Voltage                                    | 200 VDC (170 VDC for SPDT)  |               |                            |
| Breakdown Voltage                                    | 250 VDC (200 VDC for SPDT)  |               |                            |
| DC Resistive   | 10 Watts (3 Watts for SPDT)   |               |                            |
| AC Resistive   | 10 VA (3VA for SPDT)  |               |                            |
| Switching Current                                    | 0.5 A (0.25 A for SPDT)<br>1.2 A (0.5A for SPDT)  |               |                            |
| LAMP   | DERATED BY 2/3  |               |                            |
| Lead Wires   | No 24 to 18 AWG. 18" Length, Polymeric UL Recognized  |               |                            |
| Lead Wires Color                                     | SPST: 2 Blue wires<br>SPDT: Green - Common, Yellow - Normally Closed, Orange - Normally Open                            |               |                            |
| Flow Calibration                                     | (Higher accuracy units available)   |               |                            |
| Set Point Accuracy                                   | 10% maximum   |               |                            |
| Set Point Differential (Deadband)                    | 15%   |               |                            |
| Repeatability  | ± 1% maximum  |               |                            |

## CONTACT ARRANGEMENT

### Electrical Color Coding

|      |  |
|------|--|
| SPST | 2 Blue Wires   |
| SPDT | Orange - Normally Open<br>Yellow - Normally Closed<br>Green - Common |

## Certifications

### CE Compliance

Malema flow switches meets CE compliance under LVD 2014/35/EU. RoHS and REACH can be obtained from Malema on request.

### UL Recognised

1. UL and Canadian UL Recognized for use in Class I (Groups A, B, C) and Class II (Groups E,F,G), all divisions, hazardous locations. Details can be found on <http://www.malema.com/certifications>
2. Certified for ATEX and IECEX directives. Details can be found on <http://www.malema.com/certifications>
3. Certified for CE compliance under ATEX 2014/34/EU directive. Details can be found on <http://www.malema.com/certifications>

## Dimensional and Cut-Away drawings

Illustrated is the M-100 Model with 1/4" ports.

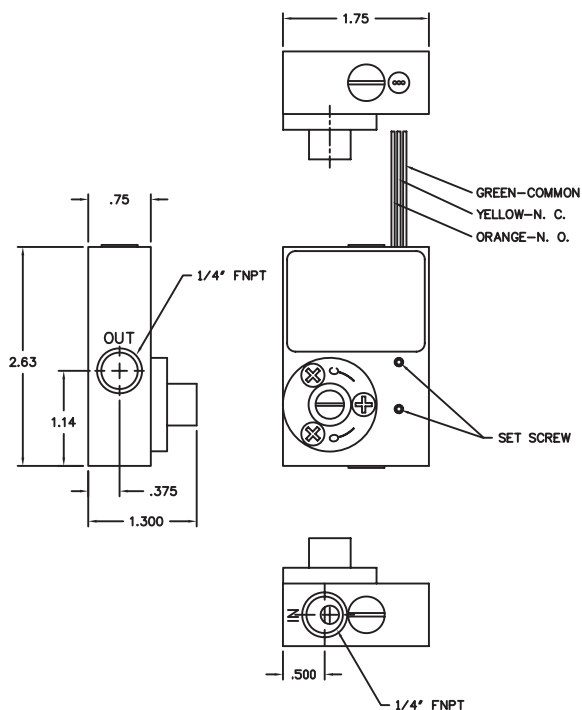

Illustrated is the M-100 Model with 1/8" ports.

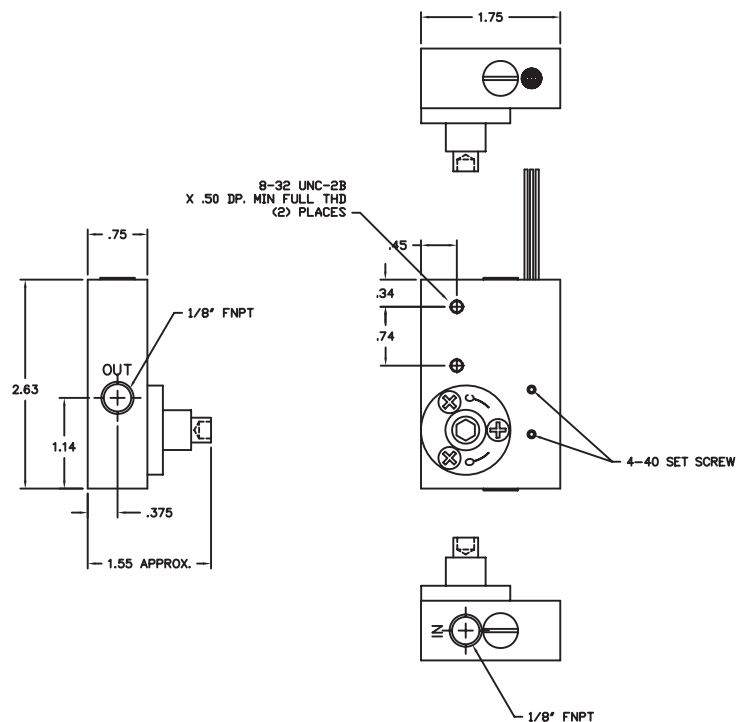

# Dimensional and Cut-Away drawings

Illustrated is the M-100 Model with 1/4" ports.

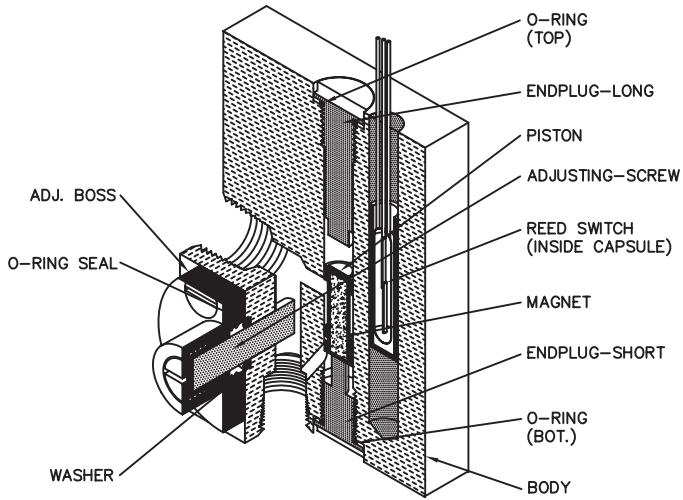

Illustrated is the M-100 Model with 1/8" ports and universal mounting.

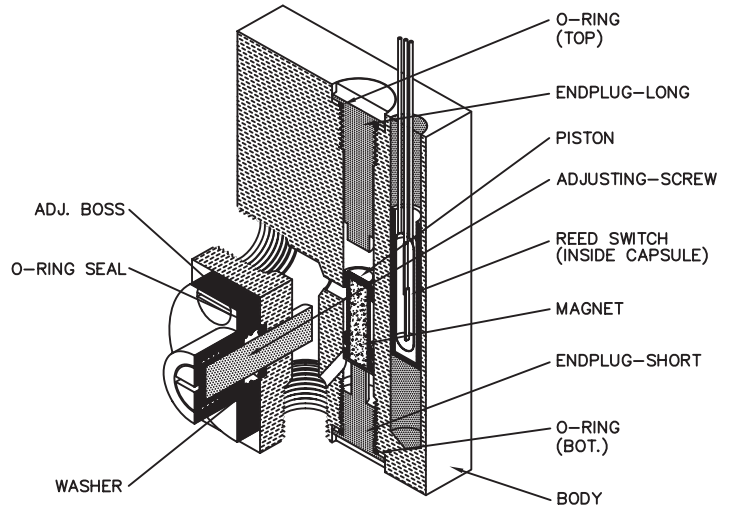

## Ordering Information

| Standard Part Numbering |   |       |   |                                    |                      |  | Options         |   |   |   |   |
|-------------------------|---|-------|---|------------------------------------|----------------------|--|-----------------|---|---|---|---|
| M                       | - | Model | - | Material                           | Port                 | Switch                                     | Flow Range      | - | Mounting  | Piston  | Seals   |
| M                       | - | 100   | - | S                                  | 1                    | 1  | 1               | - | 0   | 0   | 0   |
|                         |   | 100   |   | B - Brass<br>S - 316SS<br>T - PTFE | 1 - 1/8"<br>2 - 1/4" | 1 - SPST N.O.<br>2 - SPST N.C.<br>3 - SPDT | 1-Low<br>2-High |   | 0 - Standard (Vertical)<br>1 - Universal Mounting (with spring) | 0 - Standard* (316SS with epoxy)<br>1 - PTFE encapsulated<br>2 - All - 316SS (no epoxy) | 0 - Standard** (Viton®)<br>1 - Kalrez®<br>3 - PTFE<br>6 - Butyl<br>7 - Buna (Nitrile) |

\* Standard Piston for PTFE bodies is PTFE encapsulated.

\*\* Standard Seals for PTFE bodies is PTFE.

**Note:** The flow switch performance will be affected in the vicinity of Magnets, Electromagnets, and Ferrous metals. Hence adequate protection should be provided while installing in close proximity to such interferences or relocate the flow switch away from them appropriately.

# Warranty

Malema Sensors warrants to the buyer that its products are free from defects in materials and workmanship at the time of shipment and during the WARRANTY PERIOD. Malema Sensors obligation under this warranty is limited to the replacement of the product(s) by same product(s) manufactured by Malema Sensors or repair of the product(s) at the Malema Sensors facility. Malema Sensors products are sold with the understanding that the buyer has determined the applicability of the product(s) to its intended use. It is the responsibility of the buyer to verify acceptability of performance to the actual conditions of use. Performance may vary depending upon these actual conditions.

## Warranty Period

This warranty is in effect for twelve (12) months from the date of shipment from Malema Sensors place of business.

## Warranty Claim

If Malema Sensors products are found to be defective in materials or workmanship within twelve (12) months of the date of shipment, they will be repaired or replaced with same product at the discretion of Malema Sensors at its place of business at no charge to the buyer.

## Service and Repair

To return the products, please obtain an RMA number for the product by contacting Malema Sensors (Corporate Office), Boca Raton at (800) 637-6418 or (561)995-0595.

All returns of equipment must go to the following address:

Malema Sensors,  
1060 S Rogers Circle  
Boca Raton, FL 33487, USA

**NOTE: Specifications are subject to change without notice.**

© 2018 Malema Engineering Corporation. All rights reserved.

Malema Sensors® is a registered trademark of Malema Engineering Corporation. Malema, the Malema logo, and Malema Engineering Corporation are trademarks of Malema Engineering Corporation. All other trademarks are property of their respective owners.

Malema supplies this publication for informational purposes only. While every effort has been made to ensure accuracy, this publication is not intended to make performance claims or process recommendations. Malema does not warrant, guarantee, or assume any legal liability for the accuracy, completeness, timeliness, reliability, or usefulness of any information, product, or process described herein. We reserve the right to modify or improve the designs or specifications of our products at any time without notice. For actual product information and recommendations, please contact your local Malema representative.